

# TECHNICAL DATA



## 360COBCWIC-2

### COB IC MAGIC STRIP LED STRIP 360D 11W/M 5700K DC24V IP20 25MTS

Flexible IC LED strip operating at DC24V. Each metre is fitted with 360 COB LED chips (12 pixels per metre) and has a power consumption of 11W/m. Colour temperature: 5700K, luminous flux: 1155lm/m, IP20 protection rating. MAGIC STRIP LED strips allow the creation of a wide range of lighting effects when used with their dedicated controller (not included with the LED strip). Supplied in 25 m reels.



#### PRODUCT SPECIFICATIONS

Item code:	360COBCWIC-2
Description:	COB 360D Magic Strip LED Strip
EAN13 code:	8435724907137

#### ELECTRICAL DATA

Power:	11w/m
Pins:	3
Dimmable:	YES
Electrical insulation class:	Class III

#### LUMINOUS DATA

Color temperature:	5700K
Luminous efficiency:	105 lm/w
Lumens:	1155lm/m
LED chip model:	COB
Number of LED chips:	360 LEDs per metre
Beam angle:	120°
Light distribution:	Symmetrical
Directional:	Non-directional
Color rendering index:	>90
Luminous maintenance factor:	L95B10

#### TECHNICAL DATA

Protection rating:	IP20 (Protected against solid objects larger than 12 mm and not protected against liquids)
Operating temperature:	-20°~40°
Mounting type:	Surface
Fixture:	3M adhesive
Maximum connection:	10m

## PHYSICAL DATA

Strip	
Material:	PCB + 3M adhesive
Connection:	Includes DC connector at both ends. Transformer required.
Roll length:	25m
Weight	
Weight:	190gr
Dimensions	
PCB:	10mm
Cut segment:	83mm

## EFICIENCIA ENERGÉTICA 2023(UE-2019/2015)

F

## DIMENSIONS

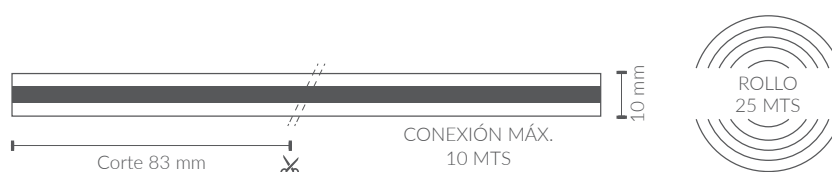

## INSTALLATION DIAGRAM

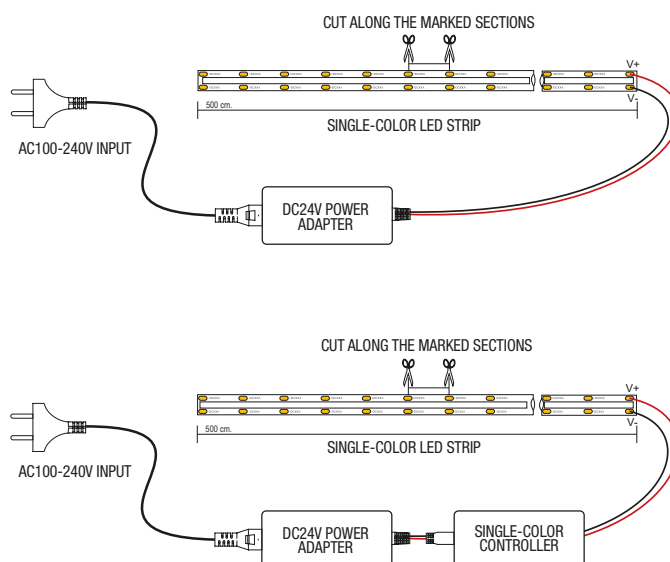

Transformer and single-color controller are not included with the strip.

**EMC directive 2014/30/EU ELECTROMAGNETIC COMPATIBILIT**

- EN IEC 55015** Limits and measurement methods for radio disturbance characteristics of lighting equipment and similar apparatus.
- EN 61547** General lighting equipment – EMC immunity requirements.
- EN 61000-3-2** Electromagnetic compatibility (EMC). Part 3-2: Limits. Limits for harmonic current emissions (equipment with input current  $\leq 16$  A per phase). (Approved by the Spanish Association for Standardisation in April 2019.)
- EN 61000-3-3** Electromagnetic compatibility (EMC). Part 3-3: Limits. Limitation of voltage changes, voltage fluctuations and flicker in public low-voltage supply systems for equipment with rated current  $\leq 16$  A per phase and not subject to conditional connection.

**RoHS Directive 2011/65/EU and Delegated Directive (EU) 2015/863**

Determination of Certain Substances in Electrotechnical Products.

- IEC 62321-1**      **IEC 62321-5**
- IEC 62321-4**      **IEC 62321-6**
- IEC 62321-7-1**    **IEC 62321-7-2**
- IEC 62321-8**

